

Mechanical loaders up to 400 N·m

7791

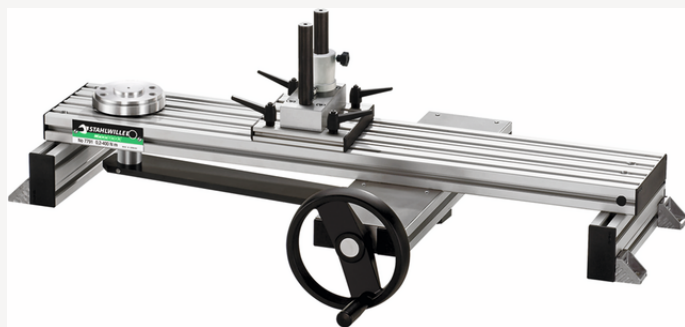

Art.No. 52110091
GTIN 4018754155439
Model 7791

Label. Mechanical calibration device Measuring-R.–400N·m f.transducer sizes 1-100

- Features.**
- **measurement possible without moving the point of application of force**
 - thanks to a specially designed force transmission system, mechanical loader No 7791 avoids the risk of the point of force application shifting during the calibration process
 - the lever below the test rail is actuated in a linear direction by the handwheel acting on a spindle
 - the linear motion is translated into a rotary movement which acts on the transducer
 - the torque wrench to be calibrated remains in the same position throughout the calibration process
 - this prevents measuring errors caused by the point of force application being moved
 - thanks to a low-friction linear ball bearing, the torque wrench is automatically levelled as it is placed in the unit
 - a further linear ball bearing ensures the contact with the torque wrench is friction-free
 - the reduction in lateral forces acting on the transducer and in the friction on the point of contact with the torque wrench results in a corresponding reduction in mismeasurement
 - protected by national and international patents

Advantages.

Measurement without shifting the point of application of force

A special force transmission system prevents shifting of the force application point during the calibration process.

Manutork® 7791 significantly reduces the force and time required for calibrations and adjustments of torque spanners.

A handwheel drives a lever which is moved linearly by a spindle and thus transmits a rotary movement to the transducer.

Due to reduced transverse forces on the transducer and a frictionless torque wrench support, measurement errors are largely avoided.

/M/a/n/u/t/o/r/k/®

Technical Drawing.

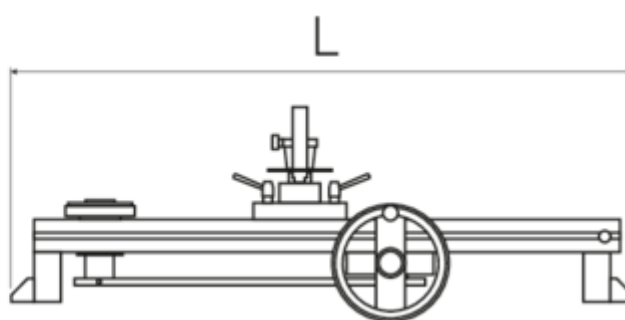
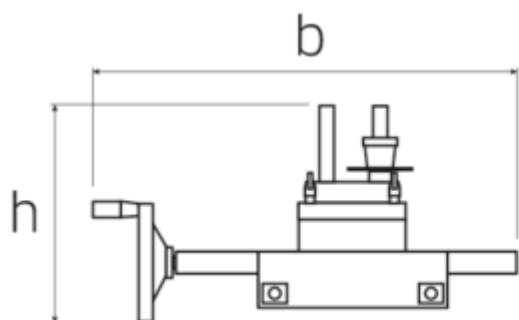

Technical Attributes.

Range N·m	-400 N·m
Width mm (b)	704 mm
Functional length (LF) max. mm	815 mm
for transducers	sizes 1-100
Height mm (h)	323 mm
Length mm (L)	1069 mm
Section width	180 mm

Logistics data.

Length (IFS)	1200
Width (IFS)	800
Height (IFS)	515
Length (packed, mm)	1200
Width (packed, mm)	800
Height (packed, mm)	515
Volume (packed, mm)	494.4 dm ³
Artikelnummer	52110091
Weight (gross, kg)	44,800
Weight PAP (kg)	0,000
Weight PVC (kg)	0,000
GTIN	4018754155439
Country of origin	GERMANY
Region of origin	Nordrhein-Westfalen
WEEE/Electrical Act	nicht ear-pflichtig
Customs tariff no.	90319000
Numbers of content units per order units	1

Variants.

Artikelnummer	Article number (ERP)	Article description (Autom.)	GTIN
52110091	7791	Mechanical calibration device Measuring-R.-400N-m f.transducer sizes 1-100	4018754155439

GTIN-Code.



STAHLWILLE Eduard Wille GmbH & Co. KG

Lindenallee 27 · 42349 Wuppertal · Germany · Phone: +49 202 4791-0 · Fax: +49 202 4791-200
info@stahlwille.de · www.stahlwille.com · Copyright by STAHLWILLE Eduard Wille GmbH & Co. KG, Wuppertal
Copyright by STAHLWILLE Eduard Wille GmbH & Co. KG, Wuppertal