

Service MANOSKOP® torque wrenches w.mount for insert tools

730N/20



Art.No. 50181020
GTIN 4018754139545
Model 730N/20

Label. Torque wrench service MANOSKOP No. 730N/20 Measuring r. 40-200N-m Tool holders 14 x 18 mm L. 467mm

- Features.**
- mount for interchangeable insert tools
 - QuickRelease safety lock
 - can be applied for either clockwise or anticlockwise tightening by turning the inserts over
 - display deviation value $\pm 3\%$ (size 2; a/2 4 %)

Advantages.

Mount for interchangeable inserts/sockets

Product highlights.



Flexible rod principle.

Mechanical torque wrenches from STAHLWILLE have a wear-resistant trigger system with a flexible rod. In contrast to conventional torque wrenches with spiral springs, the STAHLWILLE system eliminates one key work step: once the fastener has been tightened, it is not necessary to reset the wrench to »0«.



Simple.

Quick adjustment from outside, no disassembly of the torque wrench required, with two adjustment points for the maximum & minimum values.



Clicking.

When the target torque is reached, MANOSKOP® 730N provides a noticeable tactile dual stop signal.

**Clear view.**

Easy-to-read dual scale with colour differentiation between the N·m and ft.lb scales to simplify fine setting.

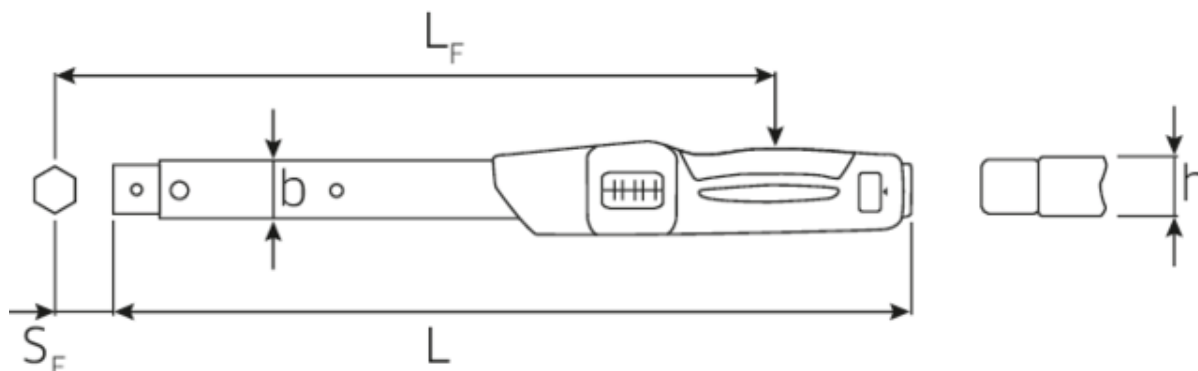
Technical Drawing.**Technical Attributes.**

Width mm (B)	28 mm
Fine scale division	1 N·m
Size	20
Size square socket [inside square drive]	14 x 18 mm
Height mm (h)	23 mm
Length mm (L)	467 mm
LF	424,5 mm
MA N·m	40 N·m
Measuring range ft·lb	30-150 ft·lb
Measuring range N·m	40-200 N·m
Nominal value N·m	200 N·m
SF	25 mm
Scale division [E1]	10 N·m
Scale division [E2]	5 ft·lb

Logistics data.

Depth mm (IFS)	495
Width mm (IFS)	52
Height mm (IFS)	52
Length (packed, mm)	495
Width (packed, mm)	52
Height (packed, mm)	52
Volume (packed, dm ³)	1.33848 dm ³
Art. no.	50181020
Weight (gross, kg)	1,370
Weight PAP (kg)	0,000
Weight PVC (kg)	0,110
GTIN	4018754139545
Country of origin	GERMANY
Region of origin	Nordrhein-Westfalen
WEEE/ElektroG	nicht ear-pflichtig
Customs tariff no.	82041100
Packing standard	1
Weight	1264 g

Variants.

Art. no.	Art. no. (ERP)	Description	GTIN
50181100	730N/100	Torque wrench service MANOSKOP No. 730N/100 Measuring r. 200-1000N·m Tool holders 22 x 28 mm L. 1363mm	4018754239955
50181080	730N/80	Torque wrench service MANOSKOP No. 730N/80 Measuring r. 160-800N·m Tool holders 22 x 28 mm L. 1178mm	4018754239948
50181365	730NII/65	Torque wrench service MANOSKOP No. 730NII/65 Measuring r. 130-650N·m Tool holders 22 x 28 mm L. 911mm	4018754239986
50181065	730N/65	Torque wrench service MANOSKOP No. 730N/65 Measuring r. 130-650N·m Tool holders 14 x 18 mm L. 890mm	4018754163991
50181040	730N/40	Torque wrench service MANOSKOP No. 730N/40 Measuring r. 80-400N·m Tool holders 14 x 18 mm L. 607mm	4018754139552
50181020	730N/20	Torque wrench service MANOSKOP No. 730N/20 Measuring r. 40-200N·m Tool holders 14 x 18 mm L. 467mm	4018754139545
50181012	730N/12	Torque wrench service MANOSKOP No. 730N/12 Measuring r. 25-130N·m Tool holders 14 x 18 mm L. 421mm	4018754139538
50181010	730N/10	Torque wrench service MANOSKOP No. 730N/10 Measuring r. 20-100N·m Tool holders 9 x 12 mm L. 386mm	4018754139521
50181005	730N/5	Torque wrench service MANOSKOP No. 730N/5 Measuring r. 10-50N·m Tool holders 9 x 12 mm L. 330mm	4018754139514

GTIN-Code.



STAHLWILLE Eduard Wille GmbH & Co. KG

Lindenallee 27 · 42349 Wuppertal · Germany · Phone: +49 202 4791-0 · Fax: +49 202 4791-200

info@stahlwille.de · www.stahlwille.com · Copyright by STAHLWILLE Eduard Wille GmbH & Co. KG, Wuppertal

Copyright by STAHLWILLE Eduard Wille GmbH & Co. KG, Wuppertal