

## Service MANOSKOP® torque wrenches w.mount for insert tools

**730N/40**



Art.No. **50181040**  
GTIN **4018754139552**  
Model **730N/40**

### Label.

Torque wrench service MANOSKOP No. 730N/40 Measuring-R. 80-400N·m Inside square stitch size 14 x 18 mm L. 607mm

### Features.

- mount for interchangeable insert tools
- QuickRelease safety lock
- can be applied for either clockwise or anticlockwise tightening by turning the inserts over
- **display deviation value  $\pm 3\%$  (size 2; a/2 4 %)**

## Advantages.

Mount for interchangeable inserts/sockets

## Product highlights.



### Flexible rod principle.

Mechanical torque wrenches from STAHLWILLE have a wear-resistant trigger system with a flexible rod. In contrast to conventional torque wrenches with spiral springs, the STAHLWILLE system eliminates one key work step: once the fastener has been tightened, it is not necessary to reset the wrench to »0«.



### Simple.

Quick adjustment from outside, no disassembly of the torque wrench required, with two adjustment points for the maximum & minimum values.



### Clicking.

When the target torque is reached, MANOSKOP® 730N provides a noticeable tactile dual stop signal.

**Clear view.**

Easy-to-read dual scale with colour differentiation between the N·m and ft.lb scales to simplify fine setting.

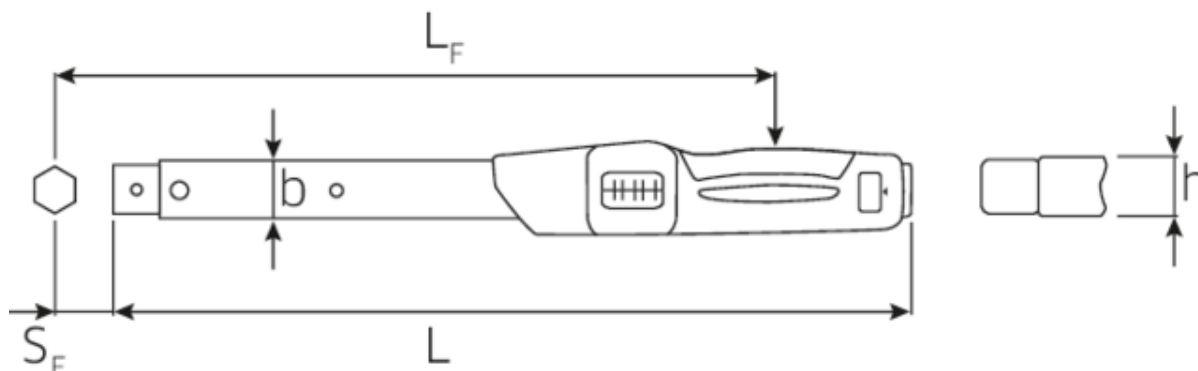
**Technical Drawing.****Technical Attributes.**

Width mm (b)	28 mm
Fine scale division	2 N·m
Size	40
Size hexagon socket [internal square]	14 x 18 mm
Height mm (h)	23 mm
Length mm (L)	607 mm
LF	564,5 mm
Lowest value of measurement range N·m	80 N·m
Measuring range ft·lb	60-300 ft·lb
Measuring range N·m	80-400 N·m
Nominal value N·m	400 N·m
SF	25 mm
Scale division [E1]	20 N·m
Scale division [E2]	10 ft·lb

**Logistics data.**

Length (IFS)	635
Width (IFS)	52
Height (IFS)	52
Length (packed, mm)	635
Width (packed, mm)	52
Height (packed, mm)	52
Volume (packed, mm)	1.71704 dm <sup>3</sup>
Artikelnummer	50181040
Weight (gross, kg)	1,775
Weight PAP (kg)	0,000
Weight PVC (kg)	0,130
GTIN	4018754139552
Country of origin	GERMANY
Region of origin	Nordrhein-Westfalen
WEEE/Electrical Act	nicht ear-pflichtig
Customs tariff no.	82041100
Numbers of content units per order units	1
Weight	1655 g

## Variants.

Artikelnummer	Article number (ERP)	Article description (Autom.)	GTIN
50181100	730N/100	Torque wrench service MANOSKOP No. 730N/100 Measuring-R. 200-1000N·m Inside square stitch size 22 x 28 mm L. 1363mm	4018754239955
50181080	730N/80	Torque wrench service MANOSKOP No. 730N/80 Measuring-R. 160-800N·m Inside square stitch size 22 x 28 mm L. 1178mm	4018754239948
50181365	730NII/65	Torque wrench service MANOSKOP No. 730NII/65 Measuring-R. 130-650N·m Inside square stitch size 22 x 28 mm L. 911mm	4018754239986
50181065	730N/65	Torque wrench service MANOSKOP No. 730N/65 Measuring-R. 130-650N·m Inside square stitch size 14 x 18 mm L. 890mm	4018754163991
50181040	730N/40	Torque wrench service MANOSKOP No. 730N/40 Measuring-R. 80-400N·m Inside square stitch size 14 x 18 mm L. 607mm	4018754139552
50181020	730N/20	Torque wrench service MANOSKOP No. 730N/20 Measuring-R. 40-200N·m Inside square stitch size 14 x 18 mm L. 467mm	4018754139545
50181012	730N/12	Torque wrench service MANOSKOP No. 730N/12 Measuring-R. 25-130N·m Inside square stitch size 14 x 18 mm L. 421mm	4018754139538
50181010	730N/10	Torque wrench service MANOSKOP No. 730N/10 Measuring-R. 20-100N·m Inside square stitch size 9 x 12 mm L. 386mm	4018754139521
50181005	730N/5	Torque wrench service MANOSKOP No. 730N/5 Measuring-R. 10-50N·m Inside square stitch size 9 x 12 mm L. 330mm	4018754139514

## GTIN-Code.





**STAHLWILLE Eduard Wille GmbH & Co. KG**

Lindenallee 27 · 42349 Wuppertal · Germany · Phone: +49 202 4791-0 · Fax: +49 202 4791-200  
info@stahlwille.de · www.stahlwille.com · Copyright by STAHLWILLE Eduard Wille GmbH & Co. KG, Wuppertal  
Copyright by STAHLWILLE Eduard Wille GmbH & Co. KG, Wuppertal