



**Werkstattmessschieber ohne Messerspitzen ohne Feineinstellung****Vernier caliper without knife-edge without fine adjustment**

- DIN 862
- Feststellschraube
- Lochmaßansatz:  
300 mm: 10 mm  
500 - 1500 mm: 20 mm
- rostfreier Stahl
- Nonius + Skala mattverchromt
- inkl. Kunststoffetui

- DIN 862
- lock screw
- nibs for inside measuring:  
300 mm: 10 mm  
500 - 1500 mm: 20 mm
- stainless steel
- scale and vernier satin chromed
- incl. box



110-22

> mm <	 mm	 inch	 mm	No.
300	0,05	1/128	90	110-22
500	0,05	1/128	150	110-34
800	0,05	1/128	150	110-36
1000	0,05	1/128	150	110-37*
1500	0,05	1/128	200	113-14*

\* ab Werk/EXW



**Werkstattmessschieber mit Messerspitzen ohne Feineinstellung****Vernier caliper with knife-edge without fine adjustment**

- DIN 862
- Feststellschraube
- Lochmaßansatz:  
250 - 300 mm: 10 mm  
500 - 1000 mm: 20 mm
- rostfreier Stahl
- Nonius + Skala mattverchromt
- inkl. Kunststoffetui

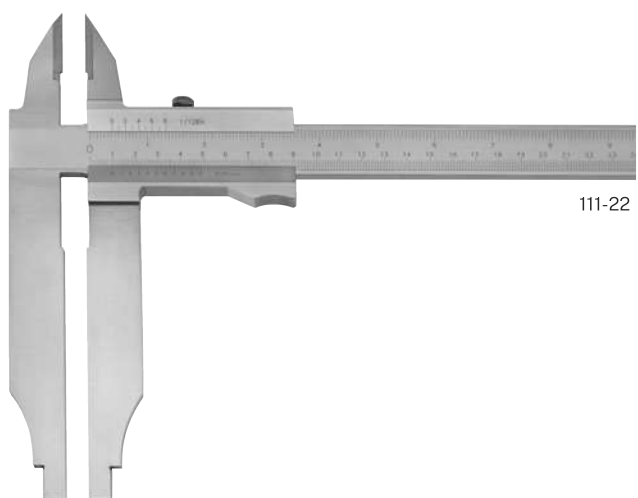

- DIN 862
- lock screw
- nibs for inside measuring:  
250 - 300 mm: 10 mm  
500 - 1000 mm: 20 mm
- stainless steel
- scale and vernier satin chromed
- incl. box



111-22

> mm <	 mm	 inch	 mm	No.
250	0,05	1/128	90	111-21
300	0,05	1/128	90	111-22
500	0,05	1/128	150	111-34
800	0,05	1/128	150	111-36
1000	0,05	1/128	150	111-37*

\* ab Werk/EXW

> mm <    Messbereich    Range  
    Ablesung    Reading  
    Schnabellänge    Length of jaws