

Messschieber für Außennuten

- DIN 862
- Auflösung 0,01 mm/0,0005 inch
- Auto off
- mit Feststellschraube
- Batterie CR2032
- inkl. Etui

Messflächen

- 1,0 mm dick, 5,0 mm tief

Caliper for outside grooves

- DIN 862
- resolution 0,01 mm/0,0005 inch
- auto off
- with locking screw
- battery CR2032
- incl. plastic case

measuring faces

- 1,0 mm thick/5,0 mm deep

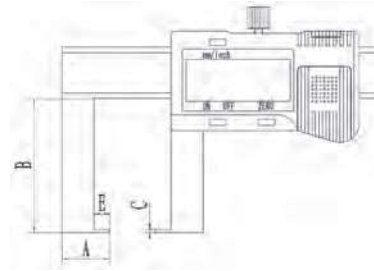

A = 15 mm
B = 40 mm
C = 1 mm
E = 5 mm

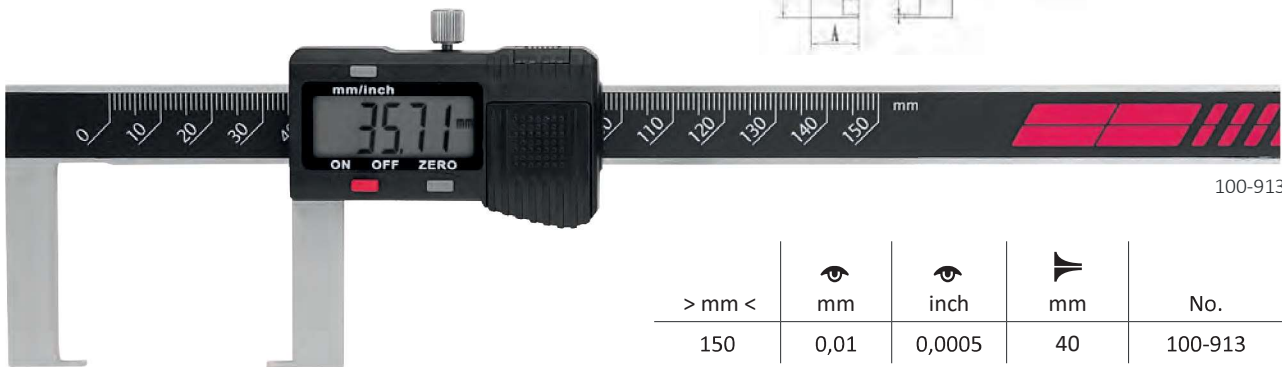

100-913

> mm <	mm	inch	mm	No.
150	0,01	0,0005	40	100-913

Messschieber für Innennuten IP67

- DIN 862
- Schutzklasse IP67
- Preset-Wert einstellbar
- Auflösung 0,01 mm/0,0005 inch
- Auto on/off
- mit Feststellschraube
- Batterie CR2032
- inkl. Etui

Caliper for inside grooves IP67

- DIN 862
- protection class IP67
- preset value settable
- resolution 0,01 mm/0,0005 inch
- auto on/off
- with locking screw
- battery CR2032
- incl. plastic case

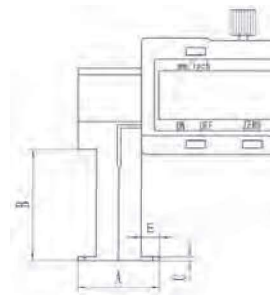

100-921	100-922
A = 22 mm	35 mm
B = 30 mm	60 mm
C = 1,0 mm	1,5 mm
E = 5 mm	6 mm

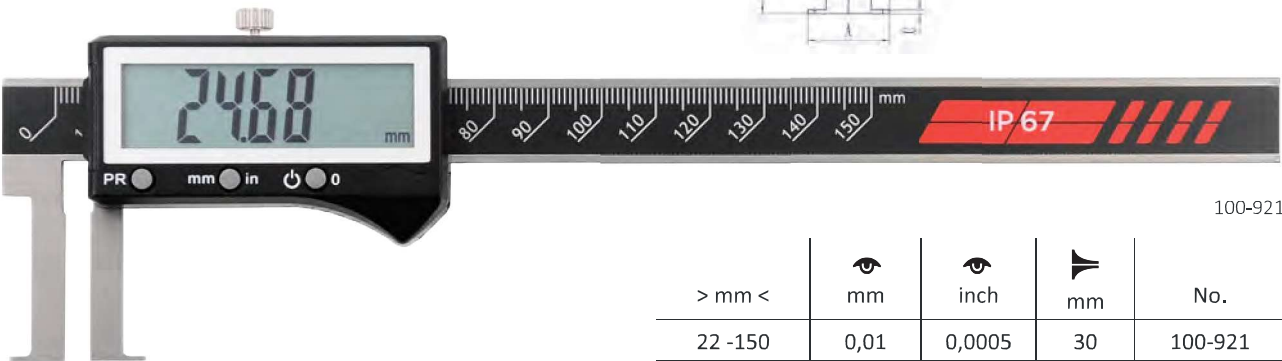

100-921

> mm <	mm	inch	mm	No.
22 -150	0,01	0,0005	30	100-921
35 - 200	0,01	0,0005	60	100-922

> mm < Messbereich Range
 Ablesung Reading
 Schnabellänge Length of jaws