

CENTERING INDICATOR GAUGE

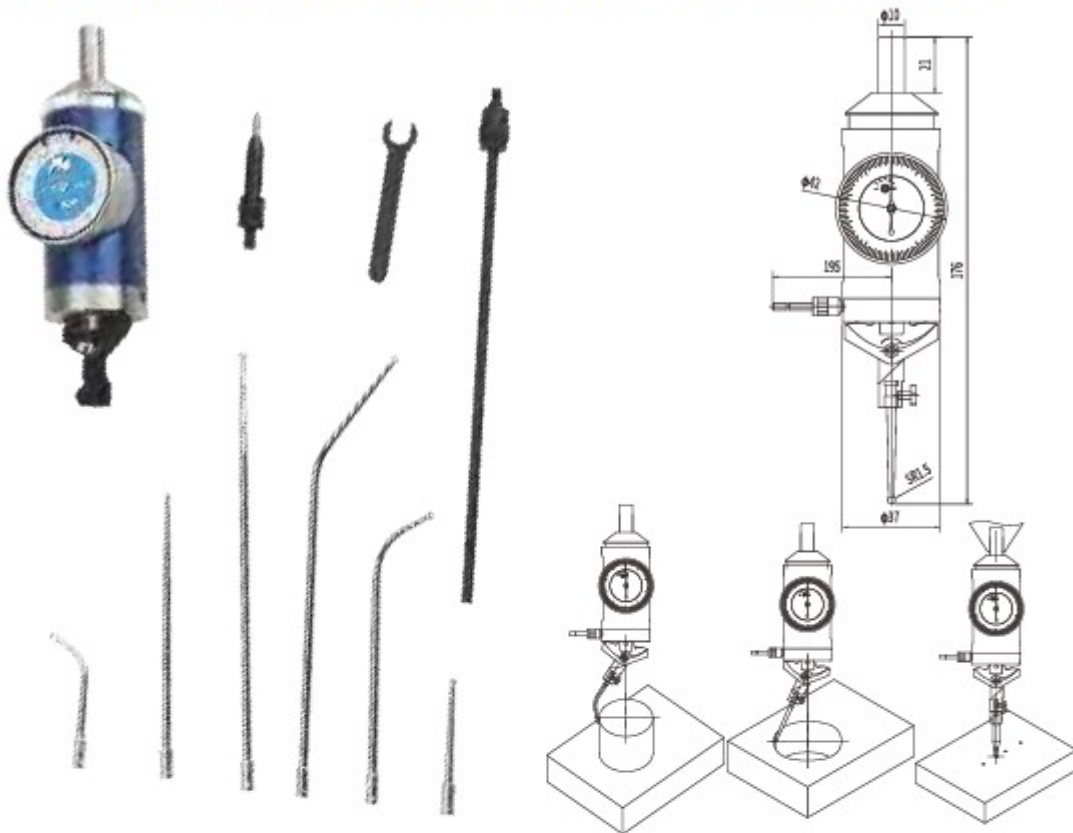

- Use this indicator to quickly center work pieces or fixtures on your bore and milling set-ups
- Determining the centres of bores and shafts
- Sturdy metal housing suitable for workshop
- Internal or external centering
- Operates at any angle from vertical to horizontal without a change
- 3 internal and 3 external feelers restraining arm
- Center point feeler
- The shank is 10mm diameter and 20 mm long
- The indicator is 180mm long with 45 mm straight feeler
- Internal diameter is from 4mm to 300 mm
- External diameter is from 0mm to 300 mm
- Straight feeler length:45 mm /100mm/154 mm
- Curved feeler length:46 mm /100 mm /154 mm
- Center point feeler length:52.5 mm

Unit:mm

Code	Range	Graduation	Accuracy
5711-6100	0-0.15"	0.0005"	0.001"
5712-1100	0-3	0.01	0.02